



Your Powerful Partner 2014



Your Powerful Partner

- 02 **Rolls-Royce Power Systems AG**
- 04 **MTU**
- 08 **MTU Onsite Energy**
- 12 **Bergen Engines AS**
- 16 **L'Orange**
- 18 **Product overview**
- 24 **Service**
- 28 **Locations**
- 30 **Sustainability**
- 32 **Employees**
- 34 **History**
- 36 **Key Figures 2013**



Dear Readers,

Don't we all wish we had strong partners? Business partners we can rely on at all times and are successful, who approach challenges with a passion and don't finish a job until they are satisfied with the result. Partners who, like the early pioneers, are pushing back the boundaries in their search to find long-term solutions to technological problems and, in doing so, achieve corporate success and write engineering history.

We can achieve a lot more together than when we try to go it alone. And that is precisely what we aim to do – as a well-coordinated system and service partner for our customers, suppliers and as the employer of our workforce. And as a strategic partner for our owner Rolls-Royce.

At the beginning of 2014, our company was renamed Rolls-Royce Power Systems AG to replace the name Tognum. With high-speed diesel and gas engines from MTU, distributed energy systems from MTU Onsite Energy, medium-speed diesel and gas engines from Bergen Engines AS and injection systems from L'Orange, Rolls-Royce Power Systems AG offers the global market a wide-ranging product portfolio. Together with our owner Rolls-Royce we can thus offer our customers an even more extensive range of products and services.

With our products, we have a corporate and engineering history that goes back over 100 years. The passion for the products we manufacture has made us what we are today. Our thirst for knowledge enables us to identify trends at an early stage and to push ahead with new developments.

We are looking forward to a future together. That is what you can expect from a good partner.

Jörg Schwitalla
Executive Board Member for
Operations, Personnel and
Integrity

Dr. Ulrich Dohle
Executive Board Chairman
and CEO

Dieter Royal
Chief Financial Officer

Dr. Michael Haidinger
Chief Sales Officer

We are driven by a **passion** for outstanding products. We provide energy and propulsion solutions combined with excellent service.

Focused expertise. Rolls-Royce Power Systems AG is one of the world's leading providers of high and medium-speed diesel and gas engines, drive and propulsion systems, distributed energy systems and fuel injection systems designed to meet the highest demands. The group, which has its head-office in Friedrichshafen, possesses extensive development and manufacturing expertise and one of the most comprehensive product portfolios on the market. The company's diesel and gas engines, diesel and gas gensets and gas turbine plants are used in over 20 areas of application. They are used to power ships, heavy land and rail vehicles and provide a reliable distributed energy supply in locations that are spread all over the world. With forward-looking high-pressure injection systems, tomorrow's emission regulations are already being achieved today.

Experienced. The group can look back on 100 years of success and a long tradition of developing new drive and propulsion systems that optimally meet the customers' needs. The company has produced a large number of innovations over the years that continue to write engineering history. Firmly rooted in tradition, Rolls-Royce Power Systems has developed into what it is today – one of the leaders of innovation in many different high-technology markets. In order to consolidate the position it has achieved even further, the group continues to develop its products, while optimising its resources, and manufactures core components in-house. This ensures that we always deliver the highest standards of quality.

Convincing solutions. Rolls-Royce Power Systems aims to set the standard for first-class energy and propulsion solutions. Regardless of whether the demand is for series-produced engines or tailor-made individual systems – the solutions from MTU, MTU Onsite Energy, Bergen Engines AS and L'Orange are among the very best available anywhere and clearly stand out from the others.



Ready for the future. In order to meet current and future emission regulations, our engineers and scientists continually carry out research into new approaches to innovative engine design and low-pollutant combustion processes. As a result, hybrid drive solutions, alternative fuels and capable engine management systems are gaining in importance. For the engines of the future, therefore, investments in our own R&D centres are an integral element of our global growth strategy.

Strong partner. The constant exchange of information and experience with customers and partners enables us to anticipate developments and to respond accordingly – before others do. Local presence has ultimately created an extensive global network: with 33 subsidiary companies and over 1,200 development, production, service and dealership locations, Rolls-Royce Power Systems is active in 130 countries on all continents. As the preferred partner for its customers, the group implements their wishes and needs – quickly, flexibly and reliably.

Our portfolio:

High-speed engines



Distributed energy systems



Medium-speed engines

Bergen Engines AS

Injection systems



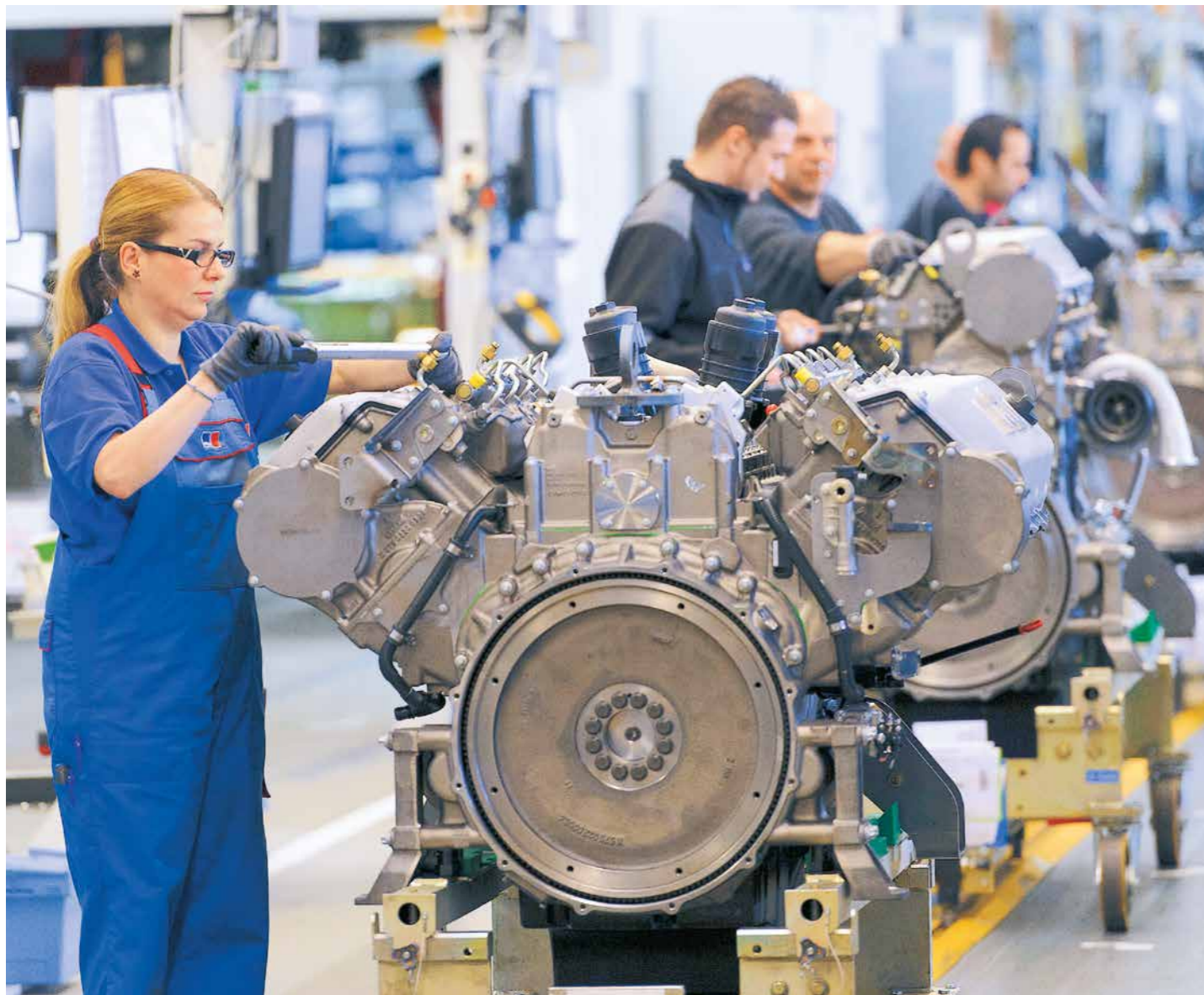

We supply **complete drive and propulsion systems** to ensure that our customers are well equipped to handle any situation.



High-speed engines



Power. Passion. Partnership.

As one of the world's leading manufacturers of large high-speed diesel and gas engines, in addition to complete drive and propulsion systems, MTU is a competent and experienced partner when the aim is to find and implement the best possible solution for the widest range of applications.

Drive and propulsion specialist. For over 100 years, MTU has achieved milestones in drive and propulsion technology. Thousands of engines have been developed, installed, tested, improved and marketed worldwide. Many years of experience and expertise contribute to create products that are best of class and the most advanced units available on the global market today. The MTU brand worldwide stands for efficient and clean diesel engines and complete drive and propulsion systems for ships, heavy land, rail and defense vehicles, and for the oil and gas industry.

Systems partner. MTU's product portfolio extends from high-quality standard systems to customer-specific turnkey plants, and includes a full range of services. As a general contractor, MTU supplies marine propulsion plants, for example, which, in addition to the engines, also incorporate subsystems such as clutch, transmission system, on-board gensets and an integrated ship automation system.

Innovation leader. MTU engines deliver power whenever required, even under extreme differences in temperature and altitude, on steep inclines and other extreme operating conditions – a sign of state-of-the-art engineering at its best. What is decisive for the leading technological position MTU products has acquired is the interplay of key technologies – turbocharging, fuel injection, engine management and



exhaust aftertreatment. MTU develops these technologies in-house and is thus in a position to ensure that all drive and propulsion components are ideally matched for optimum performance. With these core competences, MTU ensures that its customers and the company itself enjoy a financial and technological edge.

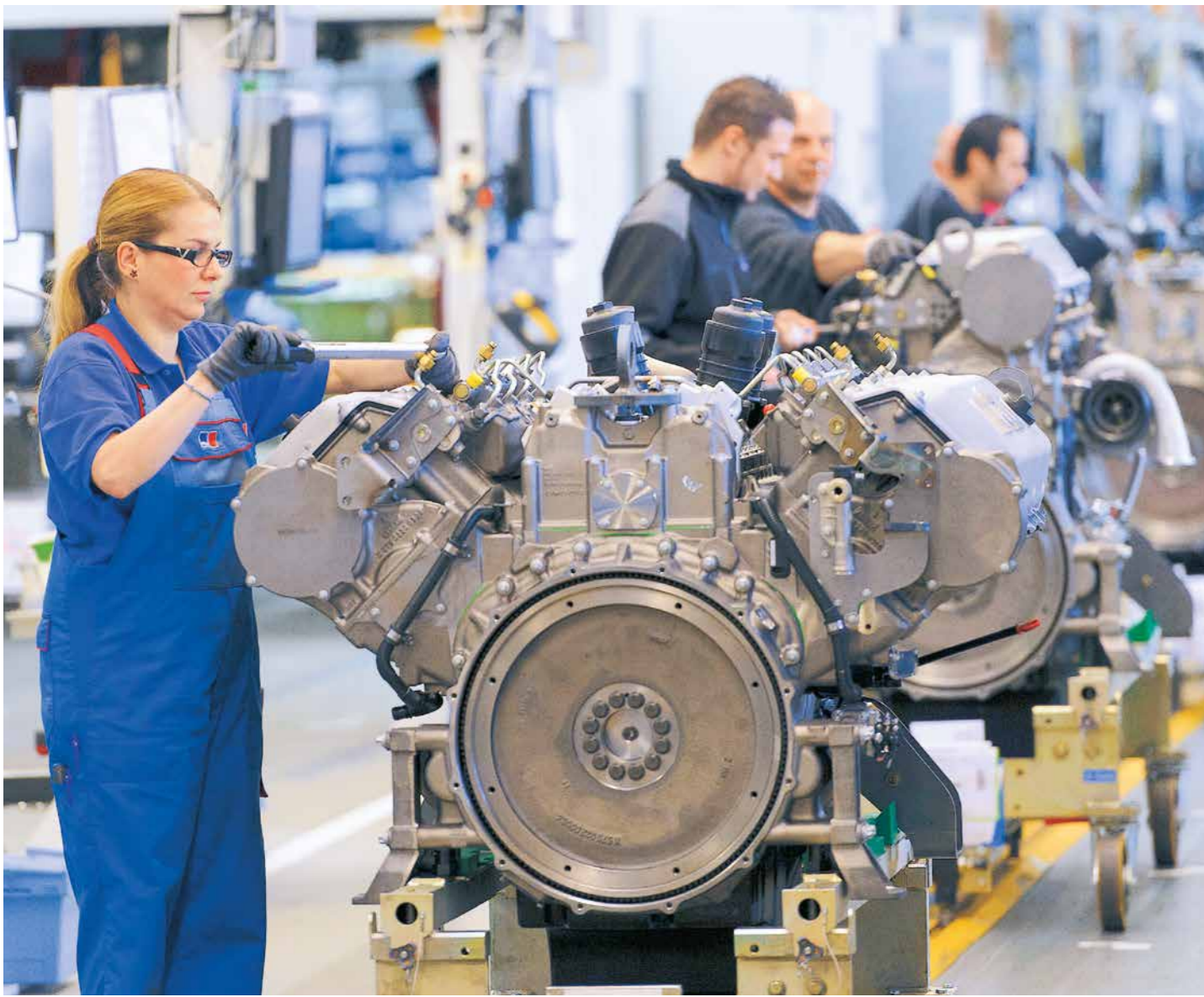

We supply **complete drive and propulsion systems** to ensure that our customers are well equipped to handle any situation.



High-speed engines



Power. Passion. Partnership.

Marine



Making waves wherever they go.

MTU propulsion systems are in service on the high seas, on rivers and lakes all over the world. They are used for both the main propulsion and auxiliary systems or as engines in gensets for on-board power supply. Highly efficient ship's automation systems ensure that components operate in complete harmony. Since 1950, over 10,000 engines have been delivered to virtually all the world's navies. Offering maximum performance under extreme conditions, they support the work carried out by navies, coast guards, police forces and other authorities. Not only are large numbers of passenger ships and ferries powered by MTU engines, but also inland waterway and coastal cargo ships, tugboats and yachts. Special assignments require specially designed propulsion systems, such as those installed in supply vessels for offshore platforms. Lifeboats, fire-fighting boats, research and survey vessels also put their trust in MTU.

Oil & Gas



Bundle of energy. For more than 30 years now, MTU has supplied the needs of the oil and gas industry. The range of products it has available includes diesel engines and gensets for onshore and offshore operations. They are used to deliver emergency power, for example, operate fire-fighting equipment, and to provide the power for pumps, mixers, drilling rigs and winches. They are designed to operate under the toughest working conditions imaginable and not only provide maximum operational safety and quality, but also deliver continuous power where it is needed – on oil platforms, for example, or at altitudes of up to 4,000 metres.

Industrial



All-rounders. In the construction industry, in agricultural and forestry applications, and in the manufacturing industry, engines are pushed to the limit. Moving forward on a solid surface is no great challenge, but when the going gets tough off the highway on rural, undeveloped terrain, MTU drives keep things moving – in road construction equipment, agricultural machinery, mobile cranes and other special-purpose vehicles such as snowcats. These are areas of application where their strengths can be exploited to the full and where they make easy work of the toughest of jobs. They have built up an enviable reputation as a result of the powerful performance, fuel economy, long service life, dependability and high availability.

Mining



The power to move mountains. Mining has its own laws and dimensions: huge stretches of land, enormous quantities, extreme temperatures, immense challenges and the unimaginable power required to get the job done. Working around the clock, day in and day out, mining companies invest time and money in the search for mineral resources, haul coal, iron and copper from mines all over the world for further processing. Man or machine – to survive in this harsh environment means being strong, hard and tough, with lots of stamina. What counts here is powerful performance, high availability under continuous load at all times and a long service life. MTU engines have been delivering just that for years in all kinds of mining equipment above and below ground – in haul trucks, underground mining trucks, mobile drilling rigs, front loaders and excavators.

Rail



On track. Rail operators place a high value on safety, punctual service and speed. On non-electrified lines, diesel engines, underfloor drive systems and complete drive systems manufactured by MTU are therefore the preferred choice for locomotives, multiple units and rail cars. As a result of their compact dimensions and the excellent power-to-weight ratio, MTU engines are ideally suited for the repowering of aging trains.

As early as the 1920s, engines were developed and manufactured by MTU's predecessor Maybach for scheduled train services. Since 1950, over 16,500 engines have been installed in rail vehicle drive systems and for on-board power generation worldwide. They have demonstrated their capabilities after covering hundreds of millions of kilometres since then. Today, with the Hybrid PowerPack and other technologies, we are investigating the potential of alternative drive solutions for the trains of tomorrow.

Defense



Well equipped. In no other field is the safety of the equipment and its crew as directly dependent on the dependability and performance of the drive system as in defense applications. With drive systems for wheeled and tracked armoured vehicles, MTU has accepted considerable responsibility in this field for many years now and has earned the trust and respect of armed forces worldwide. Tailor-made, highly integrated system solutions cover the entire range of performance requirements on the highest technological level.

MTU has delivered **276,000** engines in the last 20 years – with no less than 70,000 of these units from the company's most successful Series 2000 and 4000.



Distributed energy systems



MTU Onsite Energy systems ensure that a reliable supply of energy is made available regardless of the existing infrastructure – whenever and wherever it is needed. The power generation systems based on diesel and gas engines deliver base load, emergency standby and peak load power, and provide heating and cooling.

We address today the energy issues of tomorrow – with innovative **distributed energy** solutions.

Energy that meets the need. The increasing growth of populations and economies results in an increasing demand for energy. Not only does this mean that emerging countries in which the infrastructure is not so well developed are facing considerable challenges. In industrialised countries that are promoting the energy turnaround, one of the goals is to include renewable energies in such a way that a reliable energy supply is available at all times. With over 60 years' experience in the marketing of power supply systems, MTU Onsite Energy is making a major contribution to solving tomorrow's energy issues.



From gensets to turnkey power plants. Our product portfolio includes diesel and gas-driven gensets based on MTU engines. With diesel and gas power plants, MTU Onsite Energy offers complete turnkey solutions. Customers benefit from our comprehensive expertise in the development, project planning, production and support for such systems.

sustainable manner. Gas-driven combined heat and power plants, for example, reduce the primary energy consumption combined with low emissions and low life-cycle costs.

Efficient and environmentally friendly. Gas-based energy systems have a wide range of applications from traditional power generation to cogeneration and trigeneration. In addition to natural gas, they also operate on renewable energy sources such as biogas, sewage gas and landfill gas, e.g. in agricultural applications. They are in use wherever energy is to be used in an environmentally sound, efficient and





We address today the energy issues of tomorrow – with innovative **distributed energy** solutions.



Distributed energy systems



Emergency power



Reliable in emergencies. Storms or operational failures can result in the sudden failure of the local power grid. Everyone benefits when emergency power systems restore power within seconds. This ensures that nobody is injured and nothing is damaged and financial loss can be avoided.

Emergency power systems based on diesel engines supply small units, such as hospitals, computer centres and banks with electricity, but they also supply power to entire neighbourhoods, airports and power plants.

The portfolio also includes container gensets for mobile use. They can be transported quickly and easily from one site to the next and provide the required output in less than 15 seconds after switch-on.

Peak power



Flexibility in the extreme case. During periods of peak demand, there is a short-term need for more electricity. Distributed system solutions based on diesel and gas drive systems provide the power needed in such extreme situations and ensure that sufficient electricity is readily available. This is either fed into the local power grid (grid parallel operation) or by providing a direct supply to individual consumers (stand-alone operation). One or more power generators are connected in parallel for this purpose. The requirements to be met by the diesel engine and generator control system, particularly in terms of the frequency and load stability, are high. In addition to the extremely accurate diesel engine control system, there are tailor-made control components available that provide the operator with a high degree of reliability, precision and user-friendly operation.

Base load



Economy in the normal case. The supply of base load power requires a high degree of reliability and efficiency. MTU Onsite Energy distributed energy systems are designed to precisely comply with these requirements. Power generators based on MTU diesel engines operate around the clock all over the world and guarantee a distributed supply of energy also to remote locations – for example in mineral mines in the desert.

Many base load applications are based on the principle of combined heat and power (CHP) with gas engines from MTU Onsite Energy. These extremely environmentally friendly plants generate heat and power simultaneously. CHP plants operate on natural gas or biogas and supply heat and power to industry, to public and commercial buildings – such as swimming pools and hospitals.

85% Our diesel gensets are world leaders, with an unrivalled 24-hour average load factor of 85 per cent and an output of up to 3,310 kilovolt amperes / 3,250 kilowatts.

96% Multiple heat extraction can increase the energy efficiency of CHP plants to such an extent that an overall efficiency level of up to 96 per cent can be achieved.

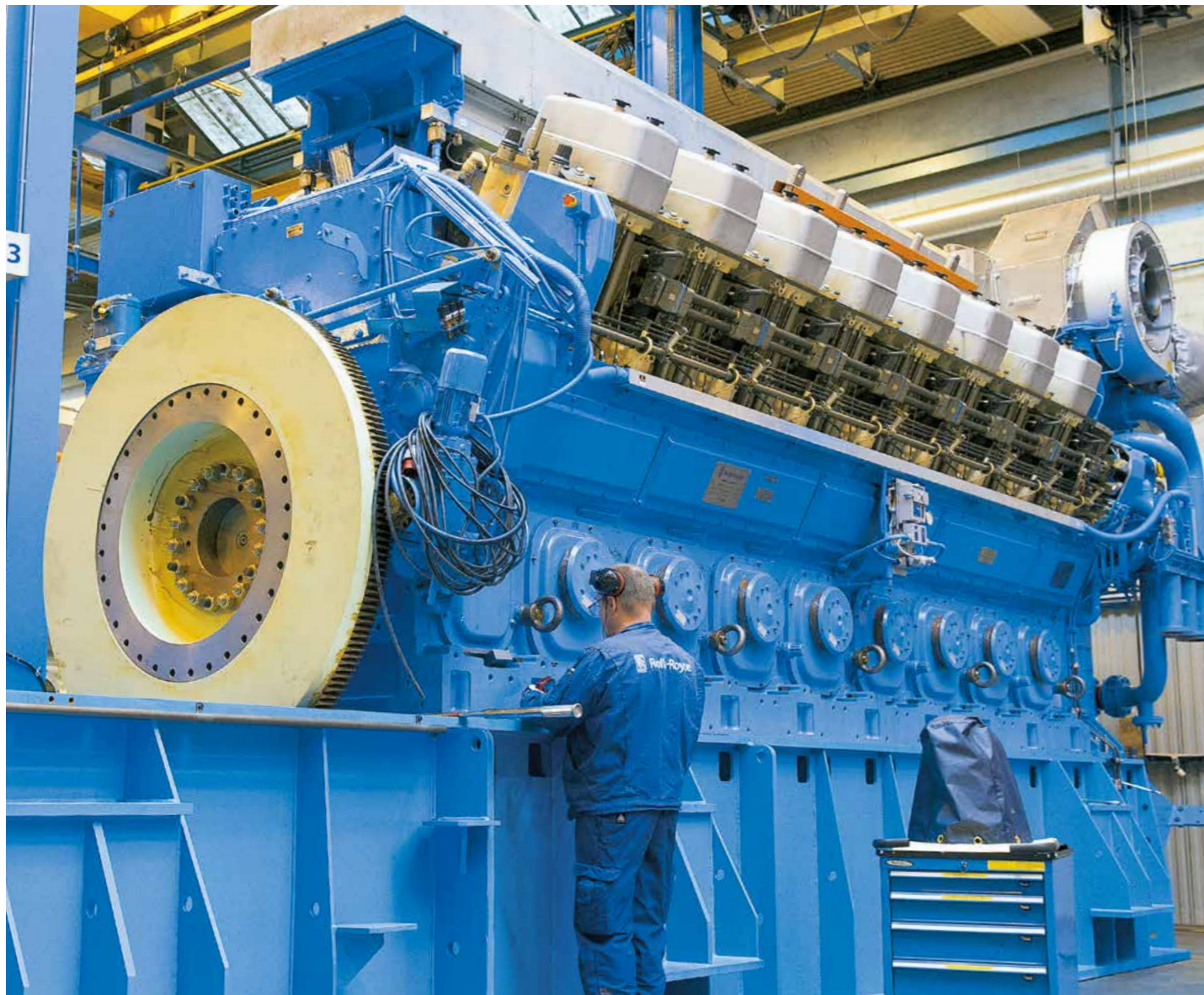

Medium-speed engines

Bergen Engines AS

In the development and production of medium-speed engines for the marine industry, Bergen Engines has acquired experience that is unique in the market – experience that Norway’s largest engine manufacturer has successfully transferred to power generation.

For a wide range of applications, we offer tailor-made **propulsion** and **energy systems** based on our proven technologies.



Long tradition. Bergen Engines has a long tradition of building diesel engines. Since 1946, they have been developed and produced in Bergen, Norway – tailor-made to meet the specific needs of ship owners and operators worldwide. In the 1980s, Bergen Engines began with the development of gas engines, delivering the first units in 1991. The company’s success is evident in sales of over 6,600 engines to customers worldwide, 4,000 of which are still in operation today. The medium-speed engines are robust, reliable and extremely powerful and meet the toughest environmental requirements.

Marine competence. Bergen Engines has been attuned to the market’s needs ever since – resulting in part from the close working relationship it maintains with ship designers and shipyards. This approach has a positive effect on the performance and efficiency of both the ships and the propulsion systems, resulting in lower fuel consumption and reduced emissions. It offers economic benefits and ensures compliance with the increasingly tougher environmental standards.

Environmental friendly power solutions. Bergen Engines has delivered engines for land power applications for nearly 20 years. Among the land power customers are Utilities, Independent Power Producers, Oil & Gas installations and Greenhouses. Since 1984 the company has developed, manu-



factured and installed more than 600 lean-burn gas engines for industrial and municipal power stations. Today the products are at the forefront of technology and quality.

Visionary. Bergen Engines builds on successful reference projects for hybrid propulsion systems in a variety of configurations, including combined mechanical and electrical propulsion systems designed to optimise fuel consumption in different operating modes. When it comes to engines using alternative fuels, such as liquefied natural gas (LNG), Bergen Engines is regarded as a pioneer.

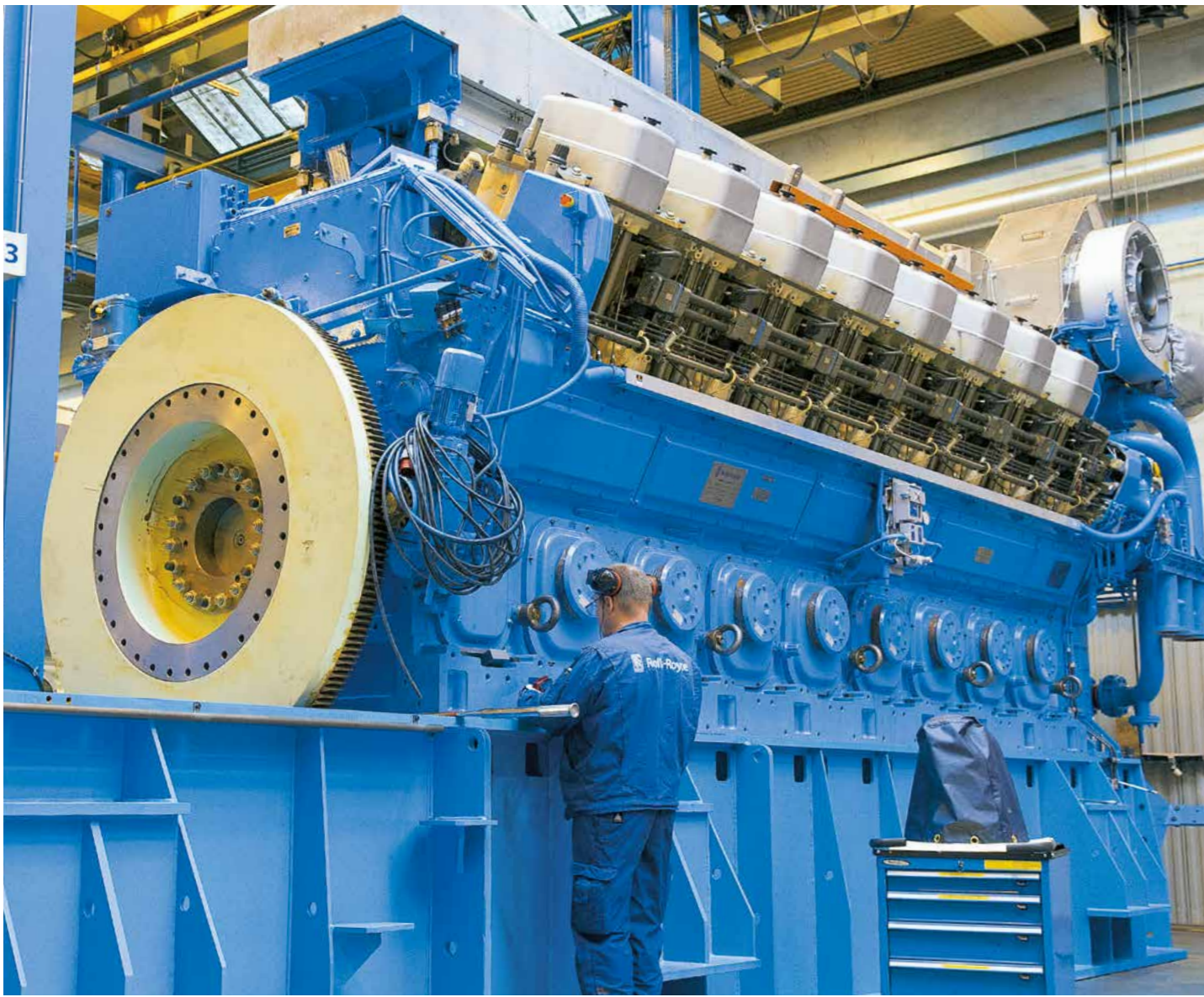

For a wide range of applications, we offer tailor-made **propulsion** and **energy systems** based on our proven technologies.



Medium-speed engines

Bergen Engines AS

Marine | Diesel



For trouble-free marine transport. The medium-speed diesel engines from Bergen Engines are regarded as particularly robust, dependable and powerful. They are used for seagoing commercial and naval vessels, where they meet the demand of ship operators and owners for high performance and for both economic and environmentally compatible operation. With their wide power range, the engines are ideally suited to the needs of cargo ships, tankers, tug boats and supply vessels operating for the offshore oil industry, in addition to fishing vessels, cruise ships, ferries and yachts. Bergen Engines supplies engines for diesel mechanical propulsion and as complete generating sets to provide diesel electric propulsion and generate onboard power that are designed specifically for such applications.

Marine | Gas



For innovative propulsion concepts. Bergen Engines is a pioneer in the development of modern lean-burn engines and, with over 500 engines sold to date, is a leader in propulsion systems based on liquefied natural gas (LNG), which are regarded as the cleanest and most efficient piston engines available on the market today. The first ship built on the basis of the award-winning "Environship" concept developed by Rolls-Royce is powered by a Bergen gas engine, as is the case with the world's first LNG-powered vessel of its type, the tug boat Borgoy, and also the cargo ship MS Høydal. Other typical areas of application include passenger and car ferries, and gas electric propulsion systems installed on offshore supply vessels. Lean-burn engines are also in great demand for ships operating in coastal waters, where stringent emission standards apply. LNG tanks, gas regulating technology, fuelling stations and automation systems are included as key components of the overall package.

The operating time of LNG-fuelled engines from Bergen Engines totals more than **20 million** hours.

Energy | Diesel



For efficient power generation. Bergen Engines meet the demand for a reliable supply of heat and power at locations around the globe – they are used to drive pumps and refineries in mines, for example, to generate power in large, distributed power plants to be fed into the local power grid and to supply power for industrial processes in factories. In combined heat and power plants, diesel engines convert as much as 95 per cent of the fuel into useful energy and thus achieve the highest efficiency levels. Bergen Engines can draw on many years of experience when it comes to finding the ideal solution, whatever the application – whether it is to cover base load and peak load requirements or to provide stand-alone operation. On request, the company will develop and implement the entire system design, including fuel tanks, cooling options and heat recovery systems.

Energy | Gas



For high energy demand. Bergen Engines supplies gas engines to local power providers, independent power producers and companies with energy-intensive processes. These include manufacturing companies in the textile, paper and food industry, for example, agribusiness operators with greenhouses and chemical companies. Applying the lean-burn concept in these fields results in high efficiency levels with low pollutant emissions and low specific gas consumption. For such applications, Bergen Engines provides a comprehensive product and service package that not only includes the gas engines required, but also the appropriate cogeneration and thermal recycling of residual waste. An additional field in which Bergen Engines is involved is the supply of power required by companies in the oil and gas industry and providing pumping and compressor stations for pipelines.



Injection systems

L'Orange
YOUR POWERFUL INJECTION

L'Orange has been one of the pioneers of advanced fuel injection technologies for over 80 years. They are used in large engines of well-known manufacturers to deliver different fuels and additives.

Our injection systems for large engines comply with the requirements for **maximum precision** and **quality**.

Always one step ahead. Engine manufacturers are faced with the challenge of constantly having to meet exhaust emission regulations that are becoming increasingly more stringent. At the same time, they are expected to optimise the performance, fuel consumption and service life of drive systems. This means that high-precision injection systems are a key factor. We supply our products to all the well-known manufacturers of large diesel and heavy oil engines for off-highway applications. And they know why.

Key technologies. L'Orange was the first manufacturer in the world to market forward-looking common-rail injection systems, one of the key technologies used today in the engines manufactured by MTU and Bergen Engines AS. With common-rail fuel injection, the combustion process can be optimised to achieve low pollutant levels combined with lower fuel consumption. Common rail enables fuel to be injected with microsecond accuracy at whatever pressure is required – regardless of the engine operating point.

Maximum precision. One thing the largest four-stroke marine diesel engines, the biggest dump trucks and the world's fastest diesel locomotives have in common – they all incorporate innovative high-pressure injection technology from L'Orange. As big as the engines and vehicles are, the tolerances with which the injection systems are designed and



manufactured remain small. High-precision manufacturing processes with tolerances of less than a thousandth of a millimetre and quality control procedures are fundamental to the high level of performance and efficiency of L'Orange injection technology.

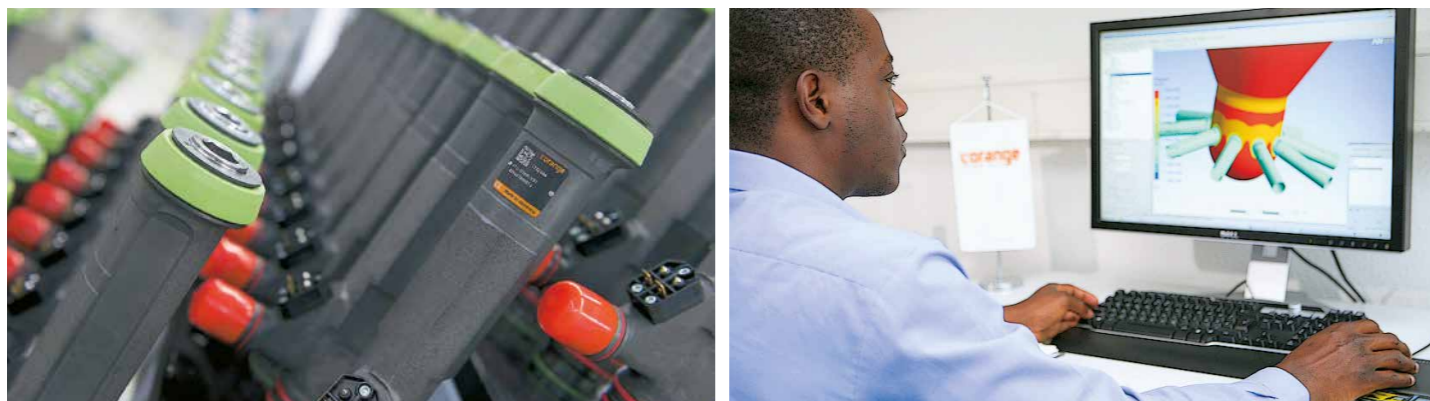





Our **products and technologies** are among the best on the market and set standards for cost effectiveness, availability and reliability.

One of the most varied product portfolios on the market: medium and high-speed diesel and gas engines with a power range of 75 to 10,000 kW.



High-speed engines

Series 900, 460, 500 75 – 480 kW  EPA Tier 3/4i, EU Stage IIIA/IIIB	Series 1000, 1100, 1300, 1500 100 – 460 kW  EPA Tier 4f, EU Stage IV	Series S60 224 – 615 kW 
---	---	--

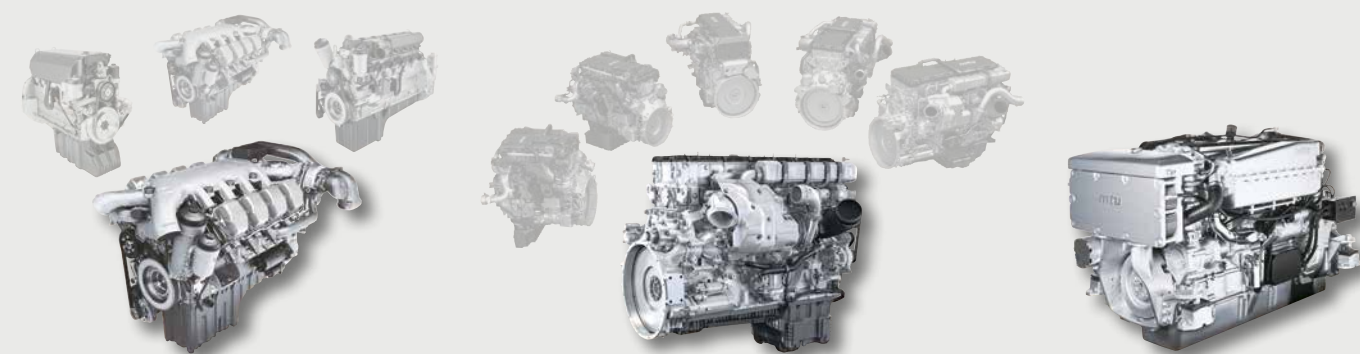



Series 1600 270 – 730 kW 	Series 2000 400 – 1,939 kW 	Series 4000 746 – 4,300 kW 
---	---	---

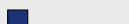

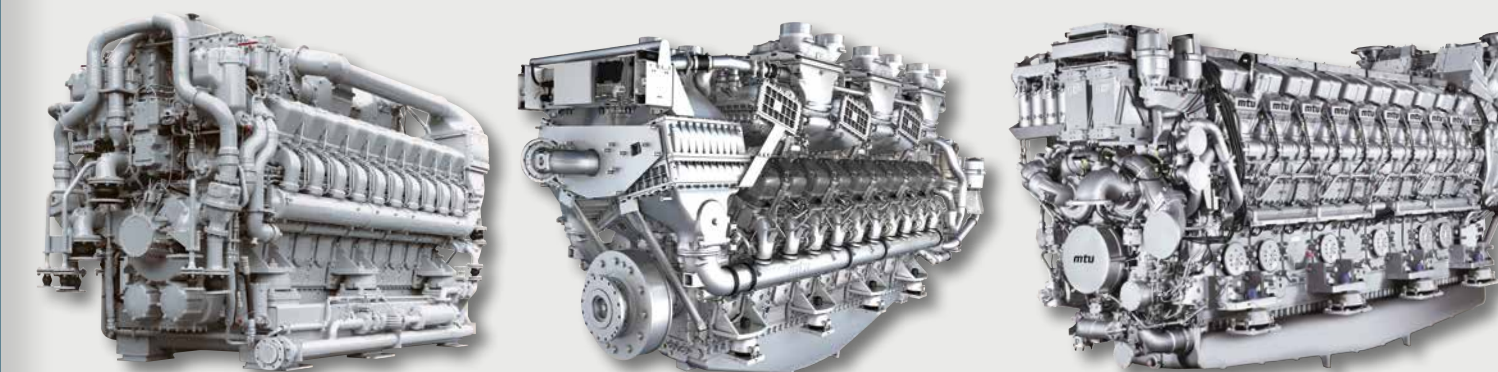
Series 956 3,900 – 6,500 kW 	Series 1163 3,600 – 7,400 kW 	Series 8000 7,200 – 10,000 kW 
--	---	--

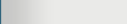
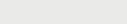

Special series for military land vehicles

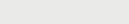
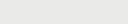

Series 106 75 – 240 kW 	Series 199 260 – 600 kW 	Series 890 410 – 1,100* kW * expected development 	Series 880 735 – 2,016 kW 	Series 870 880 – 1,325 kW 
---	--	---	--	--

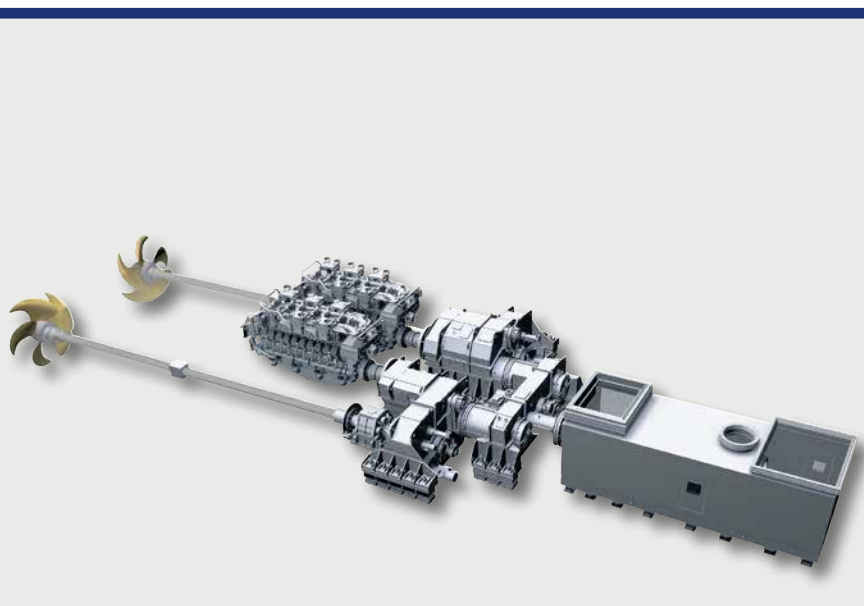

Propulsion systems



Distributed energy systems

Diesel gensets 22 – 3,250 kW electr. 	Diesel gensets for NPP 1,560 – 8,300 kW electr. 	Gas gensets 30 – 2,530 kW electr. 
---	--	--



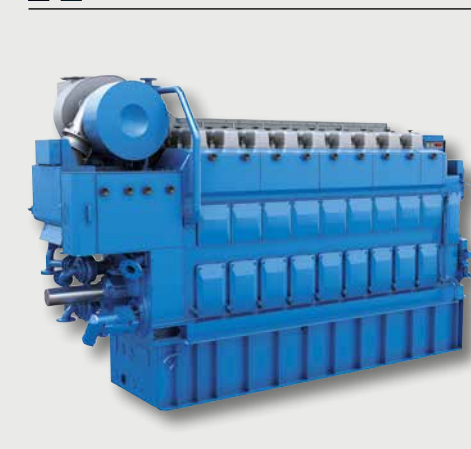

Medium-speed engines

Series C25:33 1,730 – 3,000 kW 



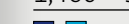

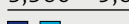



Bergen Engines AS

Series C26:33 1,460 – 3,000 kW 	Series B32:40 2,590 – 8,000 kW 	Series B35:40 3,360 – 9,620 kW 
---	---	---



Injection systems



Applications
 C & I
 Oil & Gas
 Agriculture
 Marine
 Rail
 Power generation



Whenever and wherever our customers need us – we are **on the spot** to help them. Any time, any place.



Service

The world's most demanding customers rely on Rolls-Royce Power Systems for unrivalled quality, reliability, service life and cost effectiveness. To consistently deliver these benefits, we focus on outstanding product design – not only for the equipment, but also for the full range of services that support it.

Maximizing potential. Customer satisfaction is our top priority. Our full support, including immediate assistance from our 24/7 Customer Assistance Center, ensures that customers get the most out of their equipment – maximizing performance, uptime and value. Comprehensive support is available worldwide through the group's service network.

Protecting investments. Our portfolio of service products is as varied as our equipment. From maintenance, repair and overhaul solutions to extended warranty options, every product is designed to extend system life and maximize performance.

Maintaining quality. We offer a full range of genuine parts and consumables. Available worldwide, our parts and consumables are designed to give trouble-free operation, ensuring maximum performance and long engine life.

Renewing resources. To help customers save time and money – while benefiting the environment through the reuse of materials – we offer a wide range of remanufactured engines, systems and parts that deliver the same high standard of performance, service life and quality as new products.



Comprehensive training. From preventive maintenance to diagnostics and repair, training helps customers maximize the efficiency of their equipment. Our training centers are fully equipped for a hands-on learning experience, and expert trainers who are passionate about sharing their invaluable knowledge.



Whenever and wherever our customers need us – we are **on the spot** to help them. Any time, any place.



Service

Customized service solutions. Supporting the world's most sophisticated and technologically advanced propulsion and energy systems is serious business. We serve highly-specialized industries and applications, each with unique challenges. To meet these unique needs, Rolls-Royce Power Systems offers a complete portfolio of customizable service solutions.

Planned maintenance. Unconditional engine reliability and cost certainty are especially important to mining, rail, power generation and commercial marine customers. In order to maximize availability and optimize lifecycle costs, a variety of professional maintenance solutions are available: Certified technicians do maintenance on our products on site – with details, terms and periods customized to match the individual needs of the customer. Planned maintenance solutions make it easy to predict the cost of maintenance through the lifecycle of the engine or system. For more complex systems, long-term service agreements tailored to suit each customer's operational needs ensure improved equipment availability and profitability.



Extended warranty. Many customers value additional protection beyond the standard warranty. Extended coverage offerings from Rolls-Royce Power Systems are tailored specifically to meet their needs, providing protection beyond the standard warranty. The resulting peace of mind helps these customers stay focused on the activities that matter most to them.

Remanufactured

products deliver the same high standards of performance, service life and quality as new products.

Remote monitoring. Identifying faults as early as possible saves valuable service time and helps mining customers make quick decisions regarding operational issues. Rolls-Royce Power Systems provides powerful diagnostic solutions that link customers directly to a record of their engines and sys-

tems activity through a secure Internet connection. A telemetric device stores important engine data and then transmits it in near real-time or at predetermined intervals. This information can then be conveniently retrieved remotely for analysis – even thousands of miles from the worksite.





In the complex relationships between the economy, the environment and society, our goal is to act in a **sustainable manner.**



Sustainability

Rolls-Royce Power Systems deals with issues that have an impact on our lives and the lives of future generations on a daily basis: low energy and fuel consumption, the efficient use of raw materials, reducing emissions to a minimum and dealing with people and society in a responsible manner.

Commitment. Acting in a sustainable manner is a goal firmly anchored in our corporate guidelines. We offer “sustainable solutions” and assume responsibility for the environment, people and society. We are committed to the principles of the Global Compact, which covers human rights, labour standards, environmental practices and the fight against corruption.

Business success. The activities of Rolls-Royce Power Systems are focused on long-term profitable growth. We act in a forward-looking and sustainable manner by taking into account challenges such as population growth, climate change and demographic change. The company’s business development is based on economic and social values. The shareholders, employees, business partners and other stakeholders of the company are all committed to achieving these goals.

Environmental protection. One of the key goals of the group is the protection of the environment and an improvement in our environmental performance. To us, taking global responsibility in the environmental field is a goal not limited to our company premises.

Product responsibility. Our products set standards in terms of long service life, energy efficiency, low fuel consumption and low emissions – features from which both the environment and our customers benefit. We are also working on the development of alternative propulsion technologies. Environmentally friendly gas engines operating on natural gas, biogas, sewage gas or landfill gas are used in stationary facilities. Mobile gas applications are in the planning stage. Our engineers are also researching innovative future technologies and hybrid systems. Sustainability does not end with the sale of the products. Service and remanufacturing extend their life cycle. This benefits the customer and the environment, since raw materials and energy are used efficiently.

Global environmental protection. Rolls-Royce Power Systems ensures that structures and management methods are introduced at locations worldwide to support the protection of the environment. The company works in accordance with a standard that is internationally valid. At our head-office location a special commitment to the environment and biodiversity is the MTU Environment Foundation, which was set up in 2004. The aim of the foundation is to provide support for environmental and wildlife protection projects. This is an important effort to safeguard the natural habitat of plants, animals and humans in the Lake Constance region and to maintain or restore its ecological diversity.

Responsibility for employees. Our employees are our key asset. Ongoing training, health and well-being are prerequisites for performance, quality, satisfaction and innovative power. With an all-round approach to prevention and personal responsibility, we are working in the field of occupational health and safety to establish the best conditions for our workforce. These include a comprehensive programme of courses and our own health and fitness studio in Friedrichshafen, for example. In addition, we provide family-friendly conditions for our employees.

Social commitment. We assume social responsibility as a patron, sponsor and reliable partner. Our commitment extends from education, science and sport to environmental and social issues. We are supporting the European Center for Sustainability Research at Zeppelin University in Friedrichshafen for example. And we are the main sponsor of the MTU Indoor Cup supporting young football talent.



The LIFE health management programme organised 191 events involving **3,500** participants in 2013.



Our employees have what it takes to drive innovative ideas: **pioneering spirit.**



Employees

At Rolls-Royce Power Systems, people approach top state-of-the-art technology with strong ideas. With unabated curiosity, expertise and passion, our employees create fascinating drive and propulsion technology. And at the same time establish the basis for our success.

Fascination for engineering. Motivated, superbly trained young professionals are the driving force behind Rolls-Royce Power Systems. They are the ones who have created innovative products for railway, marine and off-highway applications right from the start of the company's history. The record-breaking run of the "Fliegender Hamburger" (Hamburg Flyer) in the 1930s, the fastest crossing of the Atlantic by a powerboat in 1986, the world's first electronically controlled common-rail injection system in 1997 or the hybrid train in 2012: such achievements are the result of the ingenuity and engineering excellence of the people behind the scenes.

Modern working life. As an employer, Rolls-Royce Power Systems assumes responsibility for around 11,000 employees and their families. This includes integrating a family-friendly personnel policy into the day-to-day business operations. One example of this is the company's own MiniTu childcare centre at our head office location – the first in Friedrichshafen. This too is a pioneering effort. It comes as no surprise, therefore, that the company has already been awarded the "Career and Family" certificate for the third time.

Encouraging new talent. As early as 1919, Karl Maybach developed a standardised basic training programme for his metalworkers and set up his own training workshop – the first one ever in Upper Swabia. Since then, over 7,000 young people have successfully completed an apprenticeship or a cooperative education course at MTU Friedrichshafen or one of the other subsidiary companies. A success story for both sides, because the company has always done every-thing in its power to fill specialist and management positions, whenever possible, with its own people. In the development of new ideas, products and processes, young people just embarking on a career are as valuable a source of inspiration as are experienced employees.

International training standards. Against the current trend, the number of training positions available at Rolls-Royce Power Systems has almost doubled since the middle of the 1990s. The majority of career starters begin their apprenticeship or training at the Friedrichshafen location. And at international locations, the company is setting new standards in corporate training. Young people complete training in Norway, South Africa, Asia and in the USA to obtain the qualifications they need to start on a career – and thus ensure that Rolls-Royce Power Systems in the long term remains at the cutting edge of the industry as the technology and innovation leader.

Excellent employer. The company invests systematically and consistently in developing the professional and personal skills of its workforce. At every development stage – from trainee to qualified engineer – right from the very first day. And it has proven successful – the company has received the CRF "Top Engineering Employer" and "Top Employer in Germany" awards on several occasions. An exchange of ideas and opinions with potential recruits takes place at an early stage via joint training programmes, recruitment events and sponsoring activities, such as the "Formula Student Germany" international racing car design competition, is designed to give them an exciting inside view of day-to-day business at Rolls-Royce Power Systems and thus develop an interest in the company.

The energy, the fascination and enthusiasm for engineering, and the innovative spirit of its employees are what drive Rolls-Royce Power Systems to achieve pioneering feats. This makes the company a strong partner for its customers.



Pioneering spirit.

Those who have it spend an entire lifetime on a voyage of discovery. It ignites the passion to reach out, to make things happen and to keep pushing.

A history to be proud of.

1900 >>

1909

On March 23, the engineering pioneers Wilhelm and Karl Maybach, together with Ferdinand Graf von Zeppelin, found **Luftfahrzeug-Motorenbau GmbH**, which has its registered office in Bissingen an der Enz. The Maybach engines feature such impressive reliability and performance that they are installed in all Zeppelin airships until the early 1930s.

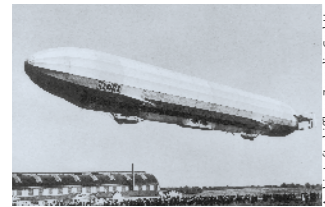

1912

Luftfahrzeug-Motorenbau GmbH relocates from Bissingen to Friedrichshafen and is renamed **Motorenbau GmbH**.



1918

Motorenbau GmbH becomes **Maybach-Motorenbau GmbH**.



1919

Maybach-Motorenbau GmbH focuses on the manufacture of petrol-driven engines for land vehicles and ships in addition to cars.

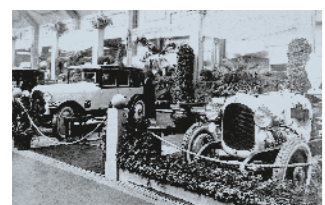

1920 >>

1924

After a five-year development period, Maybach-Motorenbau is finally able to install a complete drive system – consisting of a large high-speed diesel engine and gearbox – in a railcar developed specifically for this purpose. This marks the start of the company's in-house system expertise.

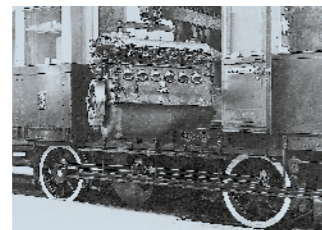

1945

Maybach sustains heavy damage from allied bombing during the Second World War; reconstruction begins.



1960 >>

1960

Close cooperation between Maybach-Motorenbau GmbH and Daimler-Benz AG in the field of large high-speed diesel engines begins.

1966

Maybach-Motorenbau GmbH and Mercedes-Benz Motorenbau GmbH merge to form **Maybach Mercedes-Benz Motorenbau GmbH**.

1969

On July 11, the large engine divisions of Maybach, Daimler and MAN merge to form **Motoren- und Turbinen-Union Friedrichshafen GmbH** – abbreviated to MTU.



1974

MTU sets up its first foreign subsidiary – MTU Singapore Pte. (predecessor of today's MTU Asia) – laying the foundation for a global presence.



1978

MTU founds **MTU of North America, Inc.** as its U.S. representative. In 1991, the representation is renamed MTU North America Inc., which is renamed MTU Detroit Diesel Inc. in 2005.

1980 >>

1987

MTU begins with the sale of Mercedes-Benz industrial engines for heavy vehicles, ships, generator sets and rail vehicles.

1995

MTU Friedrichshafen acquires from MTU München the entire shareholding in **L'Orange GmbH**, which had been founded in 1933 by Rudolf L'Orange as Gebrüder L'Orange Motorzubehör GmbH.

L'orange

1990s

MTU expands its product range to include gas engines.

1996

MTU and Detroit Diesel Corporation present their jointly developed Series 2000 and 4000 engines. The Series 4000 engine is the world's first high-performance diesel engine to feature the common-rail injection system developed by L'Orange.



History

2000 >

2001

Change in the company's name to **MTU Friedrichshafen GmbH** with a new logo.



2005/06

In December 2005, DaimlerChrysler sells its Off-Highway division to the Swedish financial investor EQT. DaimlerChrysler Off-Highway includes MTU Friedrichshafen GmbH and the Off-Highway division of Detroit Diesel Corporation in the USA, which now operates as MTU Detroit Diesel. This group of companies and brands is given the name Tognum in July 2006. The holding company is **Tognum GmbH**.

MTU acquires all the shares in the Augsburg-based provider of cogeneration plants, **MDE Dezentrale Energiesysteme GmbH**, and subsequently boosts its business in gas engines. MTU had already acquired a third of the company's shares in 2002. The company had been founded in 1977. Assembly of MTU's Series 2000 engine begins in Suzhou in China.

2007

Tognum is registered as a joint stock company, **Tognum AG**, in May and goes public on July 2. Tognum is included on the German MDAX index as of September.



The U.S. manufacturer of energy systems **Katolight Corporation**, which was founded in 1952 and has its headquarters in Mankato, Minnesota, is taken over.

2008 >

2008

The diesel engine manufacturer, **SKL Motor GmbH**, with registered office in Magdeburg, is acquired and extended to become the company's remanufacturing centre, where MTU engines and components are to be standardised and reconditioned. The company has a long tradition going back to 1838, when it was founded as "Magdeburger-Dampf-schiffahrts-Compagnie".

In September, Tognum launches the **MTU Onsite Energy** brand for distributed energy systems. MDE and Katolight now operate under the name of **MTU Onsite Energy GmbH Gas Power Systems** and **MTU Onsite Energy Corporation**.



2010

Tognum opens an engine and genset plant in Datong in partnership with China North Industries Group Corporation (Norinco). The new engine plant in Aiken in the U.S. State of South Carolina for the assembly of Series 2000 and 4000 engines, primarily for the U.S. market, goes into operation.

2011

In March, Rolls-Royce Group plc and Daimler AG launch a public takeover offer for Tognum AG through their joint venture Engine Holding GmbH. In September, Engine Holding becomes the new majority shareholder in Tognum.

As of June, the two large Tognum regional companies, MTU Detroit Diesel and MTU Asia, now operate as Tognum America and Tognum Asia.

2012 >

2012

Tognum becomes the majority shareholder in **Aggretech GmbH** in Ruhstorf, which was founded in 1995. The company is subsequently renamed **MTU Onsite Energy Systems GmbH**.

MTU Reman Technologies GmbH, Magdeburg, is the new name of SKL Motor GmbH.



2013

In January, the Domination and Profit and Loss Transfer Agreement between Engine Holding GmbH and Tognum AG comes into force. This means that Tognum is now consolidated in the Rolls-Royce plc. annual financial statements.

In March, Tognum AG becomes a fully-owned subsidiary of Engine Holding GmbH, which in May is renamed Rolls-Royce Power Systems Holding GmbH.

In July, **Bergen Engines AS**, which operates in the marketplace under the name of Rolls-Royce Power Systems, becomes a subsidiary of Tognum AG. Rolls-Royce had acquired the Norwegian manufacturer of medium-speed diesel and gas engines in 1999 and had transferred it to Engine Holding GmbH in the course of the Tognum AG takeover in 2012. The Norwegian company had been founded in 1855 as Bergen Mekaniske Verksted and initially manufactured marine and steam engines. In 1943, the company began with the manufacture of medium-speed engines.



2014

2014

In January, **Rolls-Royce Power Systems AG** officially becomes the new name of what was previously Tognum AG. The two large regional companies – Tognum America Inc. and Tognum Asia Pte Ltd – now operate as **MTU America Inc.** and **MTU Asia Pte Ltd**.

In March, Daimler AG decides to exercise the put option relating to its 50% equity interest in Rolls-Royce Power Systems and to sell the shares to its joint-venture partner Rolls-Royce.

In August, Rolls-Royce completes the acquisition of Rolls-Royce Power Systems.



Rolls-Royce Power Systems AG

2013 proved a challenging year.

Rolls-Royce Power Systems is based in Friedrichshafen in Southern Germany and, together with its worldwide subsidiaries, employs around 11,000 people. It specialises in reciprocating engines, propulsion systems and distributed energy systems. The company previously operated under the name of Tognum AG. In 2013, the former Rolls-Royce subsidiary, Bergen Engines AS, including its subsidiaries was contributed to the business.

What we do. The product portfolio includes MTU-brand high-speed engines and propulsion systems for ships, for heavy land, rail and defense vehicles, and for the oil and gas industry. Under the MTU Onsite Energy brand, the company markets diesel and gas gensets for applications such as emergency, base load, peak load or cogeneration. Bergen Engines AS manufactures medium-speed engines for marine and power generation applications. L'Orange completes the portfolio, producing fuel injection systems for large engines.

2013 financial review. The order book increased 6 per cent, with new orders of £2.7 billion (£2.8 billion in 2012). The final quarter of 2013 saw strong sales, driven by the pre-purchase of engines for industrial, including agricultural applications, ahead of the introduction of tighter environmental standards in Europe. Marine revenue is well supported by demand from navies in Asia and the US. In defense, major programmes to power military tanks provide stability despite continued pressure on Government spending. Revenue decreased 0.5 per cent with good growth in the Marine and Industrial divisions offset by lower revenue in oil and gas, medium speed engines and lower aftermarket sales. Profit increased 0.3 per cent, reflecting a strong second half.

Underlying revenue 2013

£2,831m
€3,340m

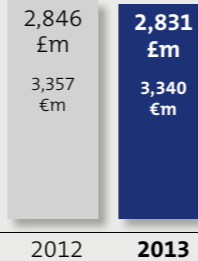

Revenue mix 2013

- 71% Original Equipment revenue
- 29% Service revenue

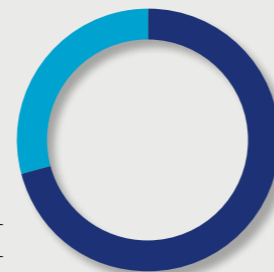

Revenue by market sector 2013

- 35% Marine
- 27% Energy
- 26% Industrial
- 12% Defense & Others

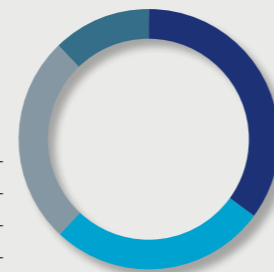

Key financial data

	2012	2013	Change
Order book in £m (€m)	1,823 (2,151)	1,927 (2,273)	5.7%
Underlying revenue in £m (€m)	2,846 (3,357)	2,831 (3,340)	-0.5%
Underlying OE revenue in £m (€m)	1,938 (2,286)	2,004 (2,364)	3.4%
Underlying service revenue in £m (€m)	908 (1,071)	827 (976)	-8.9%
Underlying profit before financing in £m (€m)	293 (346)	294 (347)	0.3%

The table above shows a trading comparison as if both Tognum and Bergen Engines had been fully consolidated in 2012 as well as in 2013.

Figures indicated in Euros were converted at a rate of €1.1797 per British Pound.

Key Figures 2013 (Rolls-Royce reporting segment "Power Systems")

Highlights: MTU Powerpacks ordered for UK Intercity Express Programme +++ Fjord Line ordered Bergen engines for cruise ferries +++ Upgraded Series 1163 engines introduced +++ UK MoD selects MTU gensets alongside MT30 gas turbine +++ Polish partnership to be created to supply and maintain cogeneration plants +++ Mining trucks powered by MTU delivered to Rio Tinto in Australia.

How we are performing. 2013 proved a challenging year. Headwinds confronting the business included the Eurozone crisis, US fiscal challenges and slowing of growth in emerging countries. General nervousness about the global economic environment led to constrained order activity within the market.

Despite these adverse market conditions, a number of significant orders and contracts were achieved.

Power Systems also benefited from contracts awarded by Chinese customer Cosco and from the UK MoD for the generator sets of the Royal Navy's future Type 26 Frigate. The Type 26 propulsion system will consist of a combination of four MTU diesel gensets and a Rolls-Royce MT30 gas turbine. These examples highlight the synergies and benefits of complementary product portfolios. MTU introduced the upgraded Series 1163 marine engines for IMO Tier II and by means of exhaust gas aftertreatment also IMO Tier III emission standards. These are cleaner and more fuel-efficient than the previous generation and offer a better power-to-weight ratio.

For the British Intercity Express Programme, MTU received orders of rail Powerpacks with Series 1600 engines. The Powerpacks will drive Hitachi's future high-speed trains which are scheduled to go into service from 2017 on Great Western Main Line and East Coast Main Line routes.

Twenty locomotives built by Chinese manufacturer, Dalian locomotive & Rolling Stock and powered by MTU engines went into service in Argentina.

China-based Xiangtan Electric Manufacturing Corporation shipped its first ever export of mine dump trucks to the Pilbara mine site in Australia for Rio Tinto. Each of the 230 metric ton trucks is powered by an MTU mining engine.

The Fjord Line shipping company ordered Bergen gas-powered engines. Its Stavangerfjord and Bergensfjord cruise ferries, both 170 metres long, are each to be equipped with four Bergen B gas engines. The engines ensure that these ships already meet future IMO Tier III limits as well as satisfying mandatory EU regulations projected for 2015, on sulphur emissions from ferries.

In addition to these contract wins, we continue to build capacity through joint ventures and partnerships. L'Orange has established a consortium with Hoerbiger for the supply of equipment for large-scale diesel and dual-fuel engines for the Asian market.

Onsite Energy and regional Polish energy supplier Kogeneracja Zachód intend to form a partnership for the supply and maintenance of cogeneration plants. Over the coming years, both companies plan on working exclusively with each other to supply small-to medium-sized Polish cities with environmentally-friendly energy from CHP plants.

Future priorities and opportunities. Our long-term growth relies on five pillars: power, propulsion, services, regional expansion and the product portfolio.

We will invest in future technologies to maintain our technological leadership. We are configuring our different engine series to meet tougher emission standards. At the same time we will improve efficiency and keep a focus on costs and cash in all other areas.



Rolls-Royce Power Systems AG
Communications
Maybachplatz 1
88045 Friedrichshafen | Germany

www.rrpowersystems.com
pr@rrpowersystems.com

August 2014, Literature Number 3300041

The Rolls-Royce name, Rolls-Royce badge and Rolls-Royce monogram logos are registered Trade Marks of Rolls-Royce plc.