

Fact sheet



Rolls-Royce

RB211 projects in power generation

Ankara, Turkey

energy



Fact sheet

Project description

The Turkish Government, faced with an increasing need to import energy, has encouraged the restructuring of the Turkish energy sector leading to full privatisation to meet the country's constantly growing power demands.

This 33MW combined cycle cogeneration plant which is located within the Bilkent University complex on the outskirts of the Turkish capital,



Ankara, supplements an existing 4MW power facility on the site and represents an investment of approximately US\$35M by Bilenerji Bilkent Power, Inc. With its entry into service in late 1999, the cogeneration plant provides 33MW of electricity plus industrial process steam to a

neighbouring paper making plant. In addition, it supplies low-pressure steam to feed the recently installed Bilkent University district heating scheme. The new cogeneration plant supplements the existing private generation plant presently operating on site. The University will secure a reliable and cost effective supply of electricity and also enjoy additional environmental and economic benefits from the steam that is supplied from the heat recovery steam generator. Previously hot water was raised using conventional heavy fuel oil fired boilers.

RB211 generating set

The well proven RB211 generating set is the centre of the project and is designed to operate on natural gas as its primary fuel but is also able to burn diesel oil as a standby fuel. The generating set is provided in two factory-assembled skid units; a driver package and a generator package. Each package is housed in an acoustic canopy designed, in this case, for indoor mounting and complete with all auxiliary systems. These can be either incorporated into the packages or provided separately as individual units, built into self-contained skid modules for ease and speed of installation and commissioning. The steam plant and control systems are mounted in the building close to the generating set packages.

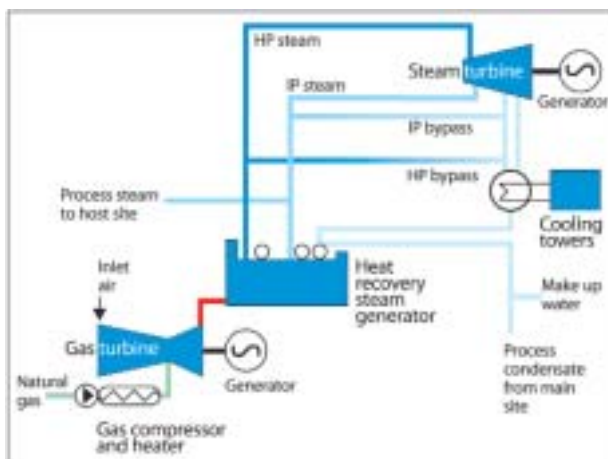

RB211 generating set assembly

The generating set is supported by a maintenance agreement to ensure that the unit continues to operate at optimum performance throughout its life. Rolls-Royce engineers work closely with the other major equipment suppliers to ensure that system outages are carefully planned and reduced to the minimum time possible.

Over 300 RB211 industrial engines are operating in land-based duties throughout the world making it one of the most successful adaptations of an aero engine in its range.

Rolls-Royce representation in Turkey:

Rolls-Royce International Limited

Akaretler, Siraevler,
Süleyman Seba Caddesi No 43,
80680 Besiktas, Istanbul, Turkey
Tel: +90 (0)212 236 9216
Fax: +90 (0)212 236 9220
www.rolls-royce.com

Technical information

Maximum power operational data

Maximum gross electrical power output	33,000kWe
Gross electrical efficiency	46.3%
Gross electrical heat rate	7,775 kJ/kWh
Net process export steam flow	1.25kg/s

District heating operational data

Gross plant electrical output	29,000kWe
Gross plant combined heat and power efficiency	67.6%
Gross plant heat rate	5,325kJ/kWh
Net process export steam flow	6.8 kg/s

Conditions

Ambient temperature	12°C
Altitude	1,035 m
Steam export pressure	15.6 bar(g)
Steam export temperature	205°C



Rolls-Royce



Rolls-Royce Power Engineering plc

Ansty, Coventry, CV7 9JR,
England
Tel: +44 (0)24 76 624132
Fax: +44 (0)24 76 624477
www.rolls-royce.com

© 2001 Rolls-Royce plc

The information in this document is the property of Rolls-Royce plc and may not be copied or communicated to a third party, or used for any purpose other than that for which it is supplied, without the express written consent of Rolls-Royce plc.

Whilst this information is given in good faith, based on the latest information available to Rolls-Royce plc, no warranty or representation is given concerning such information, which must not be taken as establishing any contractual or other commitment binding upon Rolls-Royce plc or any of its subsidiary or associated companies.